

BIZERBA

... closer to your business

Intelligent combinations for all-round profits Bizerba Scales and Checkout Systems K-class flex ...



Klassflex
... The Key to Added Value ...

The idea of the Bizerba K-class is to constantly reinvent itself. To find ways of meeting your specific requirements. To identify market trends and find practical solutions for them quickly. To combine technical feasibility with economic acceptability. K-class flex meets these demands with spectacular success.

Based on the building block principle ...

flex



Flexible as never before in aspects such as functionality, ergonomic design and positioning

K-class flex permits you to freely combine individual components, e.g. printers, touchscreens, weighing terminals and to produce well designed solutions that are as space-saving as they are ergonomic. You can implement everything – from the information terminal with or without printer or a checkout-only function through to a complete scale.

Thanks to a fully modular design, the Bizerba K-class flex offers applications that were previously not available. Stand-alone or totally new counter concepts within a scale network. In an identical attractive design and centrally controlled from the back office using the Bizerba .RetailFramework just like the entire K-class series.



K-class flex carrier system



K-class 7" customer screen



K-class 12" sales assistant touchscreen



K-class 12" customer screen



K-class flex scale type LA KF



KScalePad – ultra flat scale for integration in the sales counter



K-class flex CPU/control unit



K-class printer



K-class cash register

All this and
much more
– that's
K-class flex ...



Information terminal
for consumer advice



Information terminal with
printer option





POS terminal with multimedia advertising option and connection to scale network



Price labelling and POS terminal with multimedia advertising

Checkout and scale combinations with screens for operator and consumer



By separating the screen and load cell, each K-class flex variant can be ideally adapted to a wide variety of operating processes. As the printer, cash register and CPU can simply disappear under the counter, the footprint required for counter installation is minimal.

This is what you always wanted ...



What you want, where you want it, how you want it

A counter top area of 100 mm in diameter is enough to integrate the K-class flex in the existing shop concept, including the sales assistant/customer screen. Additional swivel, tilting and height-adjustable supports help to place the screen in just the right position. All components in the Bizerba checkout/scale solution – such as the screens and printer – are equipped with standard VESA mount attachments.

Open for scores of future expansion options

The central processing unit (CPU) guarantees that your K-class flex solutions will grow with your specific requirements. For example, you may want to connect a small receipt printer at a later date or an additional external printer for delivery notes or other components (e.g. scanner, TFT screens, etc.). Even WLAN connections and software upgrades are quick to implement using the intelligent control system.

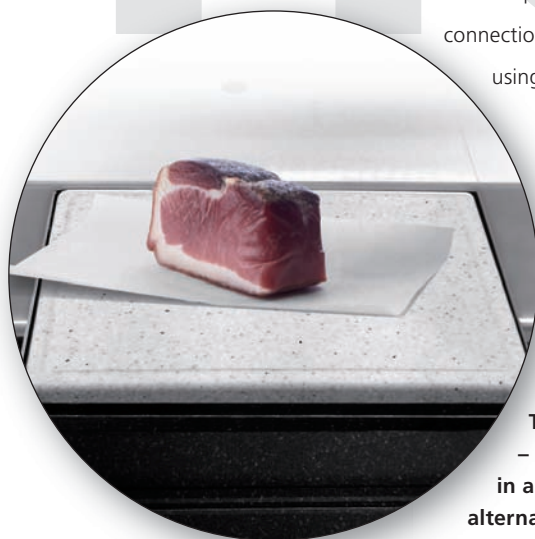

KScalePad

**The Bizerba KScalePad
– a ultra flat scale for integration
in a counter. A space-saving
alternative to our K-class flex Scale.**



The CPU incorporating an Intel® processor combines high computing power with low power consumption and runs whisper quiet as it is fanless. It is designed as a netbox and also powers all Bizerba components, which means that only one power socket is required at the POS. By using standard software, it merges perfectly in the system network of the entire K-class series – from scale to checkout.

Simply install,
plug in and serve ...

flex





Connections CPU including power supply for all connected components



Connections 12" sales assistant touchscreen with integrated WLAN (option)



Connections 12" or 7" customer screen

Installed based on the Plug and Play principle

The CPU can be quickly put into service using cable connectors. A socket strip offers enough connections for all devices that require no external power supply adapters. For this reason they are very simple to replace.

Very easy to maintain and repair

The CPU is designed for long life even in continuous duty. The housing can be removed without the use of tools. This makes it much easier to connect components.

Space-saving using the piggyback process

The load cells and central processing unit on the K-class flex are separate from each other. However, the two modules have identical dimensions and can therefore be combined into a compact unit.



Bizerba K-class flex can be integrated without any problem in existing system management architectures. Their operating system is based on POSready retail standards or Linux. They are therefore fully compatible with Bizerba scale software and with the Bizerba *.RetailFramework* software family.

■ Better advice, faster service,
higher sales ...

flex



The benefits speak for themselves

Convenient serving from scale to checkout

- One mode of operation for all terminals
- Data updates for checkout, scale and information terminal at one location
- Central evaluations for ERP and cash accounting
- Immediate explanation of bill checkouts
- Use of Bizerba values and advertising for cross-selling and upselling through Bizerba .RetailFramework
- Expansion of terminals with additional software functions
- Complete integration of devices in existing software installation

Welcome to the Open World of Bizerba

The .RetailK operating system communicates using the TCP/IP protocol and supports customary remote service tools. It is also capable of integrating software made by other manufacturers.

Active sales and success control

Within a modular system solution, the Bizerba .RetailFramework software family offers you intelligent functions and applications to achieve transparent data management – from incoming goods through to checkout. It comprises the ERP software applications WinCWS® and .RetailVision to design user interfaces, label designs and label layouts. With .RetailImpact, the content administration tool, you can download, update and control Bizerba Values from .RetailMall.

In our eyes, a scale is the pivotal device at the Point of Sale. You should be in constant dialogue with operators and provide them with support in all sales situations.

Only when you succeed in demonstrating advisory skills can you build up trust and arouse interest in making additional purchases.

In the limelight of customer interest

Bizerba Values is our comprehensive solution concept to create advertising content, cross-selling and consumer advice. It supplies K-class flex with product information, recipes, images and films:

- Using Bizerba .RetailImpact, the content administration tool, you can download advertising and consumer information over the Internet, link this information to your products and conduct updates on the K-class flex.
- Bizerba provides the content on its online portal .RetailMall – tailored to your industry.
- Everything the ideal salesperson needs to keep in mind when it comes to product knowledge, nutrition tips, recommended cooking information and even hygiene know-how can be saved on the CPU hard disk.
- Advertising campaigns and videos can be loaded and controlled at any time from the touchscreen on the operator side.

... log in, select, download ...



... manage, schedule ...



... link ...



... apply



CPU

■ **Colour**

Signal white / silver

■ **Processor**

Intel 1.6 GHz

■ **Memory**

1 GB RAM, 160 GB SATA hard disk, of which: 64 MB for PLUs, receipt journal etc. Compact Flash 4 GB (optional)

■ **Interfaces**

- 1 x Ethernet RJ-45, max 100 Mbit/s
- 4 x USB 2.0 Highspeed
- 2 x serial RS 232 (COM 1 and COM 2)
- 1 x loudspeaker port (external)
- 1 x RJ 12 for one cash register
- 1 x 12.1" touchscreen on sales assistant side
- 1 x 12.1" or 7" customer screen
- 1 x Bizerba printer
- 1 x external load cell
- Wireless LAN (optional)
- Port for another cash register (optional)

■ **Operating system**

Linux (K-Software), POSready (CE II Software)

The scales that print well (thermal, label and linerless printers)

- Linerless saving effect (prints only as much paper as necessary)
- Double printer variants
- More print width (64 mm instead of 52 mm) for 12 mm more information (optional on all devices with label printer)
 - Legal obligation to print more information (information for allergy sufferers, nutrition values)
 - Increase sales and revenues by printing recipes and recommendations

Touchscreen operator unit/customer screen

- Brilliant display on colour screen thanks to 24 bit colour depth
- The scale creates trust (transparency for the end consumer)
- Advertising – window on more sales and revenues
 - Full-screen advertising – arouses interest for more
 - Long-term advertising – even while serving
 - In-house advertising for more sales, external advertising for more revenue (advertising cost subsidies)
- Fixed using standard VESA 75 support systems, variable tilt and swivel using support system
- **12" operator colour touchscreen**
12.1", 307 mm diagonal, screen area 246 x 185 mm
TFT LCD with CCFL backlighting (16.7 million colours)
Screen resolution: 800 x 600 pixels (SVGA)
Touchscreen resolution: 4096 x 4096 pixels, 5-wired resistive
- **12" customer colour screen**
12.1", 307 mm diagonal, screen area 246 x 185 mm
TFT LCD with CCFL backlighting (16.7 million colours)
Screen resolution: 800 x 600 pixels (SVGA)
- **7" customer colour screen**
7", 178 mm diagonal, screen area 155 x 92 mm
TFT LCD with LED backlighting
Screen resolution: 800 x 480 pixels (WVGA)

Support system

- 100 mm diameter footprint
- Screw mounting 75 x 75 mm
- Standard screen mounting
- Optional support bracket for printer
- All components mounted using VESA 75

K-class flex weighing range

Type KF load cell

Weighing range 6/15 kg **Interval** 2/5 g **Minimum load** 40 g

- Dimensions 295 x 295 x 62 mm
- Bell shaped load plate made of brushed stainless steel

Type 18A load cell

Weighing range 6/15 kg **Interval** 2/5 g **Minimum load** 40 g

- Dimensions 340 x 275 x 130 mm

Type 150/350 load cell

Weighing range 6/15 kg 15/30 kg 30 kg 30/60 kg 60 kg 120 kg 60/150 kg

Interval 2/5 g 5/10 g 5 g 10/20 g 10 g 20 g 20/50 g

Minimum load 40 g 100 g 100 g 200 g 200 g 400 g 400 g

- Dimensions 400 x 500 x 92 mm
- Bell shaped load plate made of stainless steel
- Main/platform frame made of steel (zinc plated) or made of stainless steel

KF dimensions

Complete design

- VESA support bracket for screens with additional support arm for printer
CPU - 12" operator touchscreen - 7" customer screen - Printer - Type KF

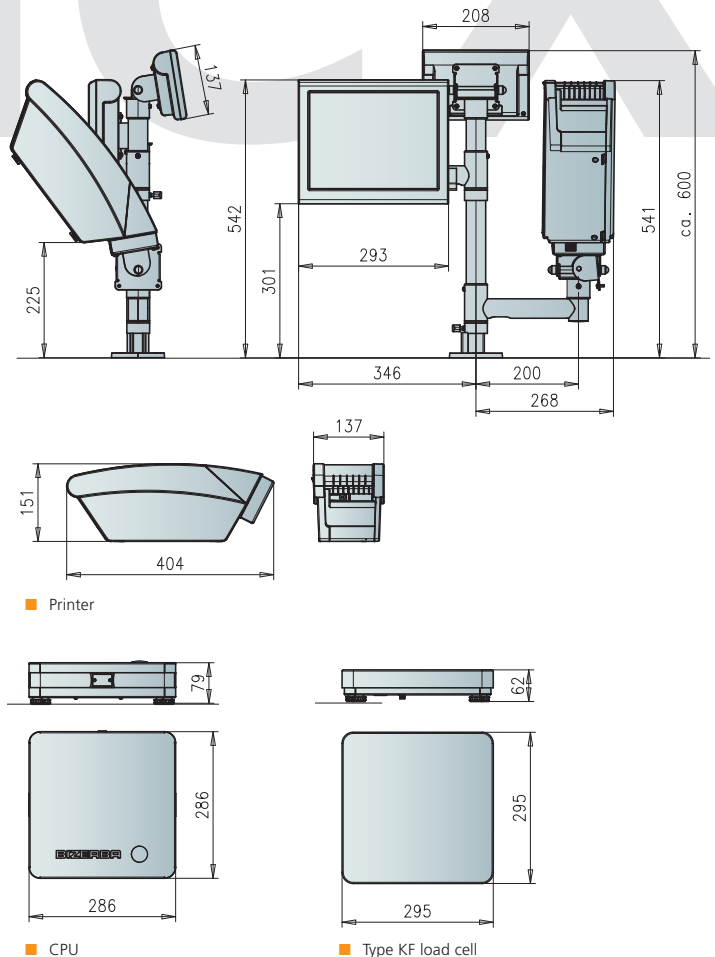

Members of the Bizerba Group

Bizerba GmbH & Co. KG
Wilhelm-Kraut-Straße 65
72336 Balingen
Germany
Tel. +49 7433 12-0
Fax +49 7433 12-2696
marketing@bizerba.com
www.bizerba.com

Bizerba (U.K.) Limited
Bizerba House
Eastman Centre
Eastman Way
Hemel Hempstead
Herts HP 2 7 DU
U.K.
Tel. +44 1442 24-0751
Fax +44 1442 2313-28
sales@bizerba.co.uk

Bizerba USA Inc.
31 Gordon Road
Piscataway
New Jersey 08854
USA
Tel. Office +1 732 565-6000
Tel. Service +1 732 565-6001
Fax +1 732 819-0429
us.info@bizerba.com
www.bizerbausa.com

Bizerba Canada Inc.
2810 Argentia Road #9
Mississauga,
Ontario L5N 8L2
Canada
Tel. +1 905 816-0498
Fax +1 905 816-0497
ca.info@bizerba.com
www.bizerba.ca

Bizerba South East Asia
Pte. Ltd.
1 Fifth Avenue #02-05
Guthrie House
Singapore 268802
Singapore
Tel. +65 6465-1900
Fax +65 6468-0481
bizerba@bizerba-sea.com
www.bizerba-sea.com