

UBERT GASTROTECHNIK
GMBH
Gewerbegebiet Ost + Nord
D-46348 Raesfeld

Telefon: +49 (0) 28 65 / 602-0
Fax: +49 (0) 28 65 / 602-102
Internet: www.ubert.com
e-mail: info@ubert.com

Myhrvold Nordic Danmark



DHTG31

Produktdatenblatt

Benennung	Deli Heiße Theke Gourmet Line
Maße [mm]	B 1072 x T 1057 x H 848
Elektrischer Anschluß (EA)	400V, 3/N, 50Hz, 3.62kW
Nettogewicht	127kg
Ausführung	Gehäuse komplett aus Edelstahl mit Vollglasaufsatz. Klappbare Panoramascheibe mit gasfederunterstützten Hebehilfen, verspiegelte Schiebescheiben. Sektionen mit getrennt steuerbarer Oberhitze. Befeuchtetes Umluftsystem mit thermostatischer Regelung. Optimale und effektvolle Ausleuchtung durch Quarzstrahler. Glasklare Sicht durch auf die Frontscheibe ausgerichtete Ausblasdüsen.
Zubehör gegen Mehrpreis	3 x 1/1 -100mm GN-Behälter; 3 x 1/3 -100mm GN-Behälter, Unterbau

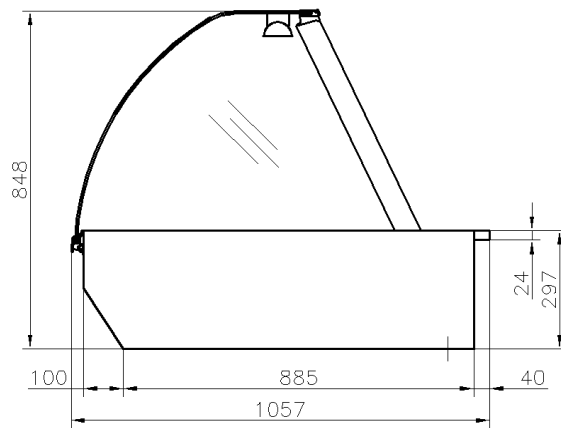
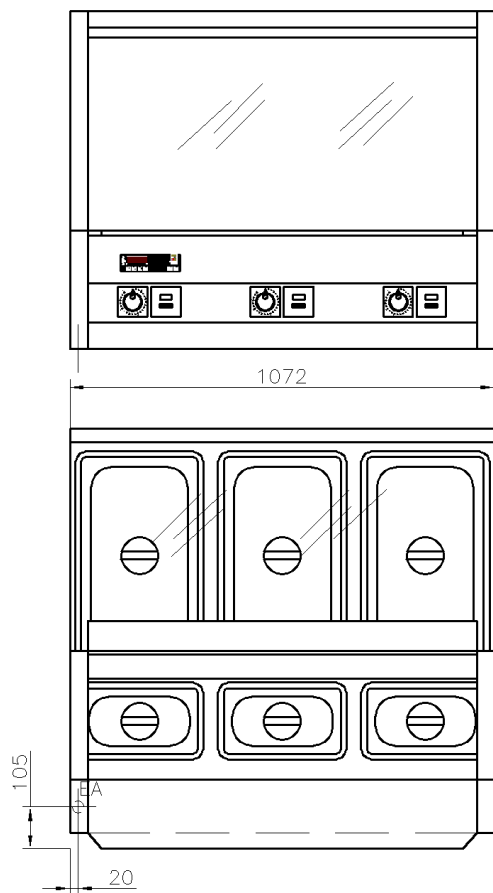

UBERT GASTROTECHNIK
GMBH
Gewerbegebiet Ost + Nord
D-46348 Raesfeld

Telefon: +49 (0) 28 65 / 602-0
Fax: +49 (0) 28 65 / 602-102
Internet: www.ubert.com
e-mail: info@ubert.com



DHTG31 Specification Sheet

Name	Hot Deli Display Cabinet Gourmet Line
Dimensions [mm]	W 1072 x D 1057 x H 848
Electr. Connection (EA)	400V, 3/N, 50Hz, 3.62kW (or 230V, 1/N, 50Hz, 3.62kW)
Net Weight	127kg
Description	Case completely made of stainless steel with full glass top. Frontglass with lift-up hinge, supported by gas rams, mirror-coated slidingdoors. Top heat separately adjustable per GN-section. Humidified air circulation system. Temperature controlled by thermostat. Optimized illumination by halogen lamps.

Accessories at extra cost

3 x 1/1 -100mm GN-pan; 3 x 1/3 -100mm GN-pan, Base

